

**BUILD &
DRIVE**

RC

Voiture de sport
Sports car

8+



Buki
France

ZAWARTOŚĆ

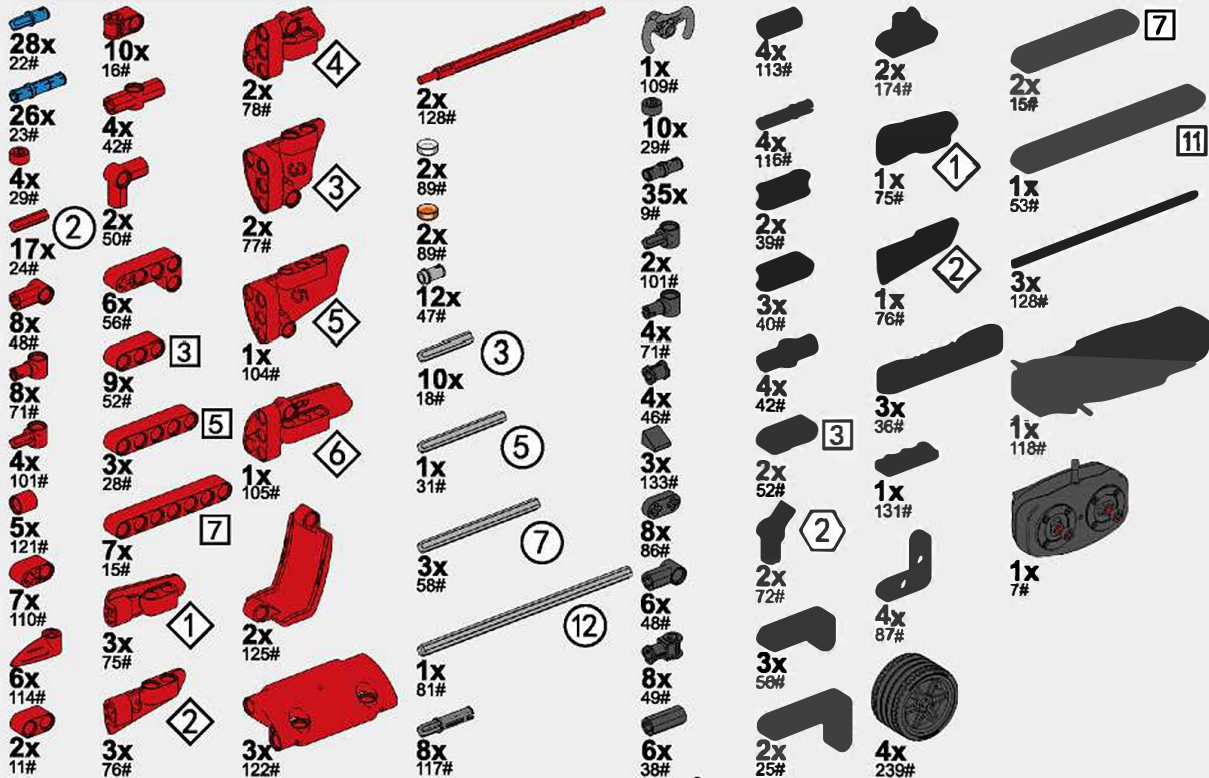

A

Supercar
Superdeportivo

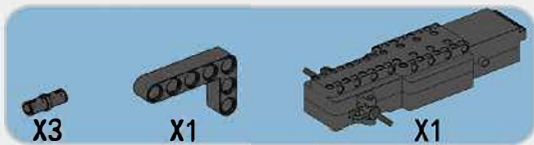
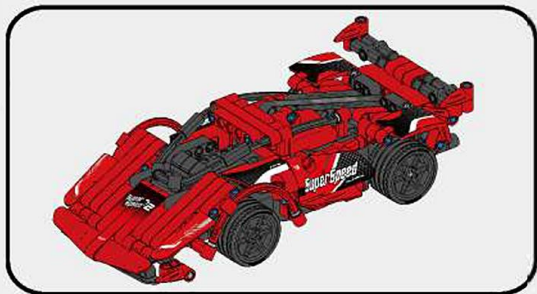

1

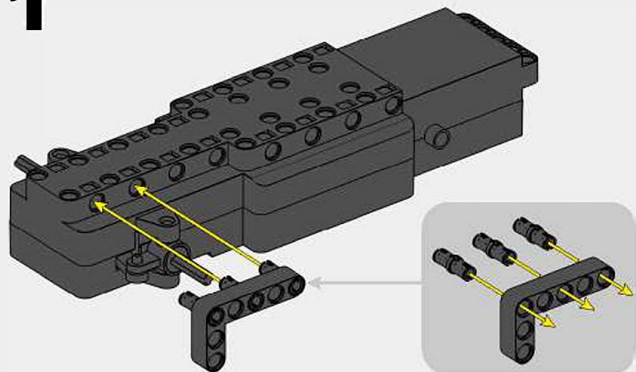

2

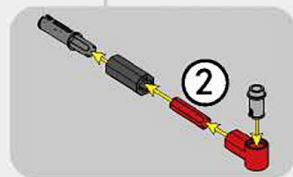
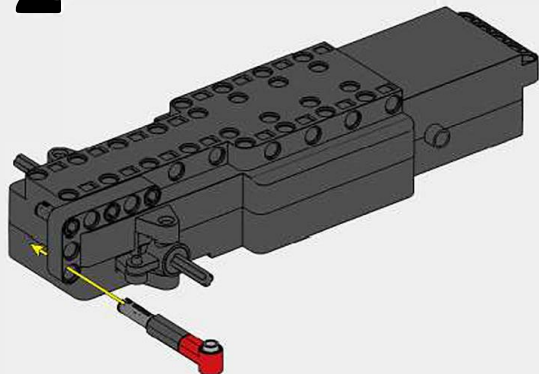



3

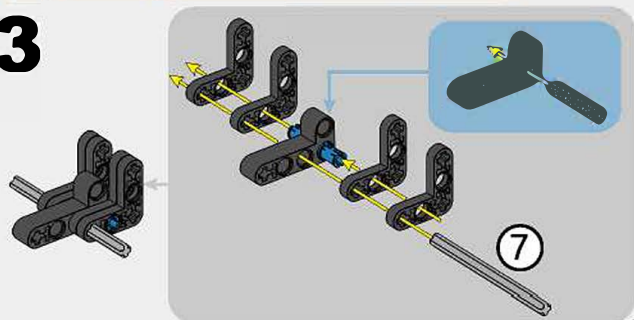

5

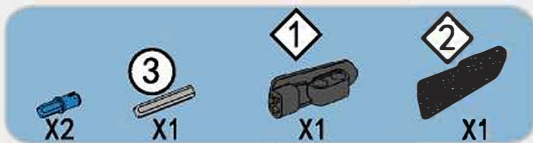
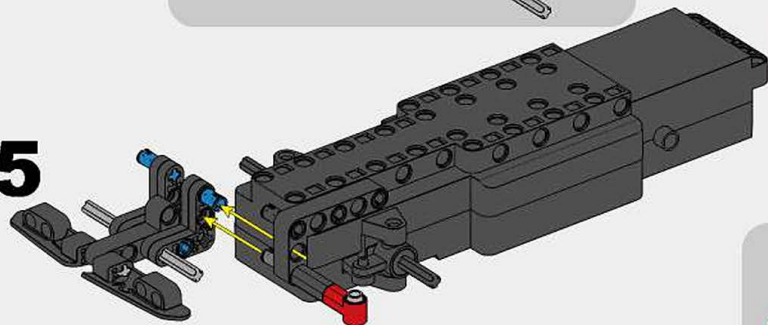

4

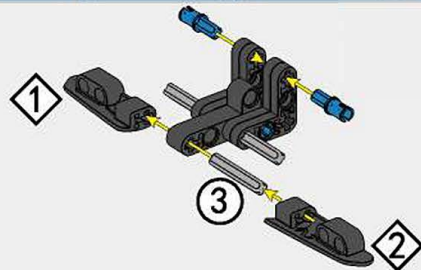

6

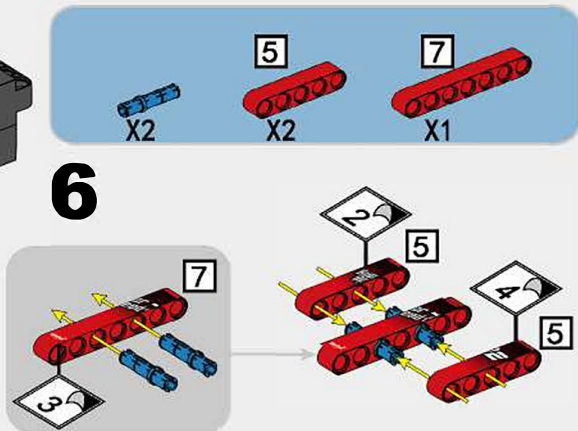

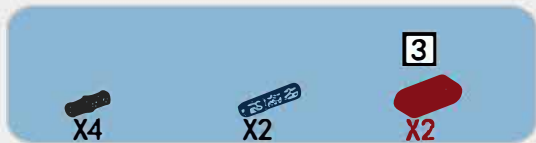

7

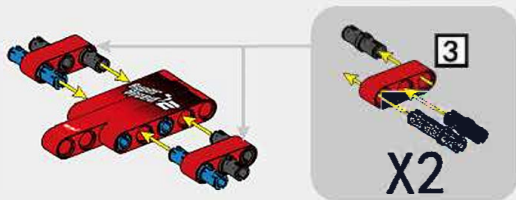

8

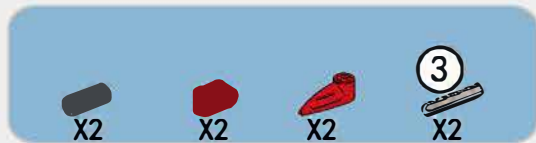
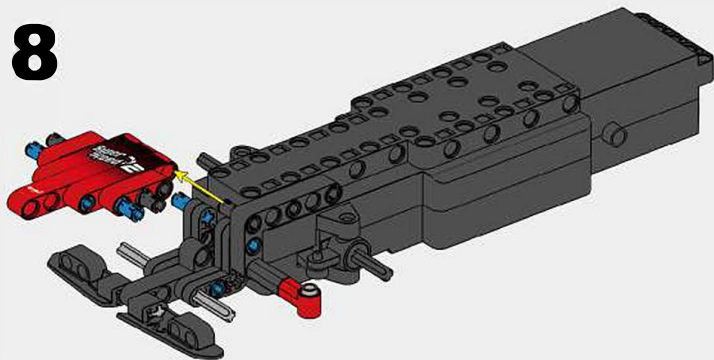

9

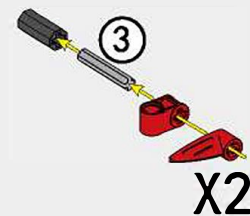

3



X1

10

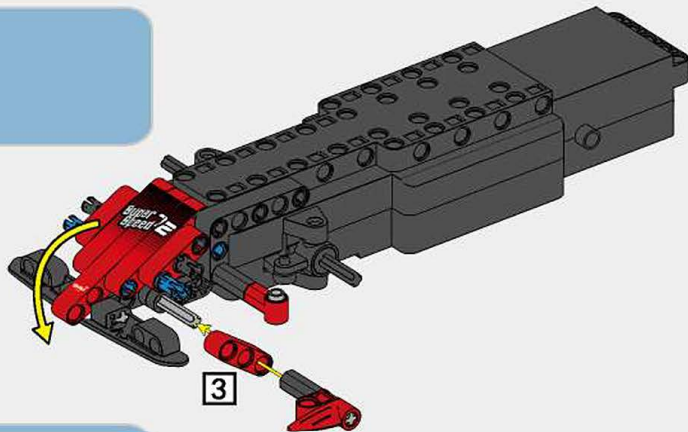

3



X1

11

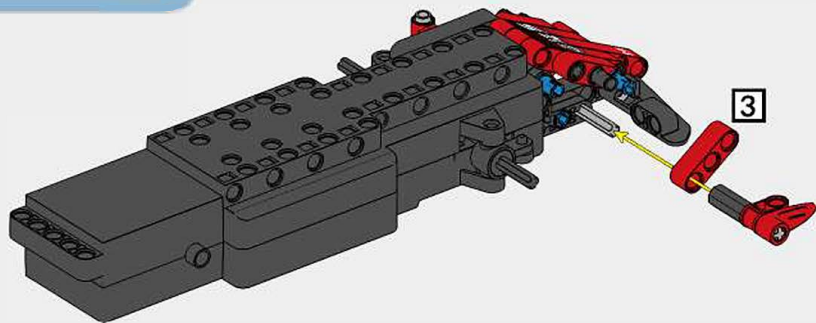

X3

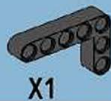

X1



② 1:1

12

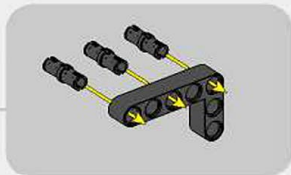
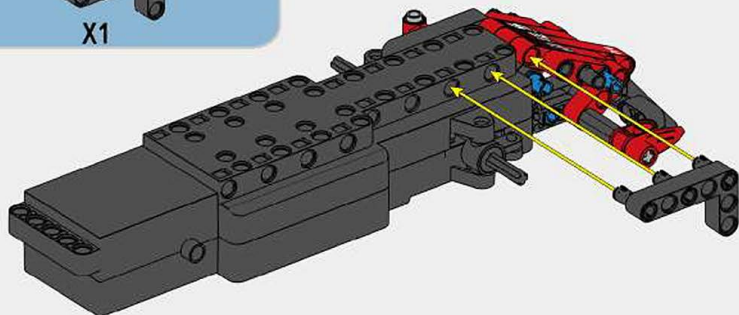

X1

②

X1



X1



X1



X1

13

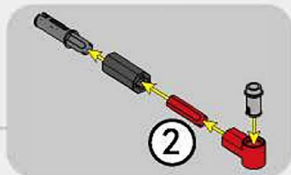
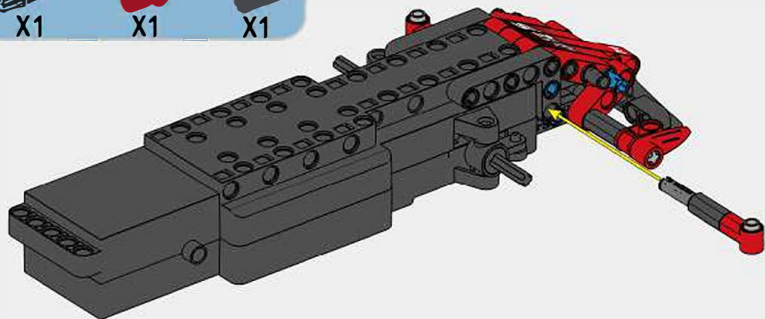

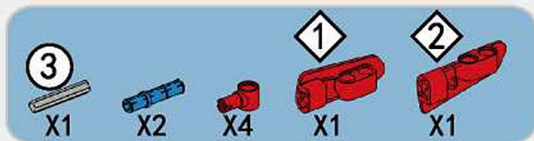

14

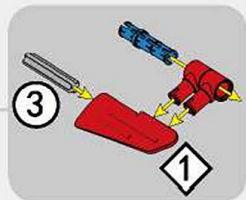
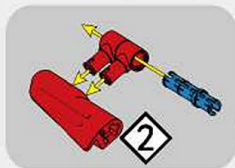
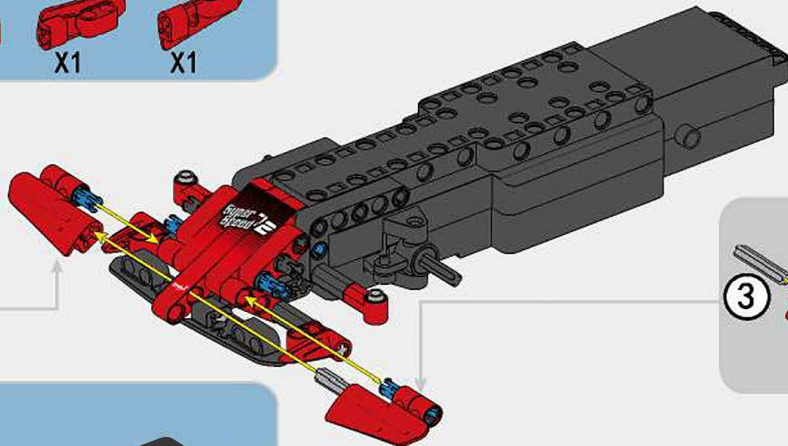

15

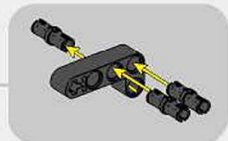
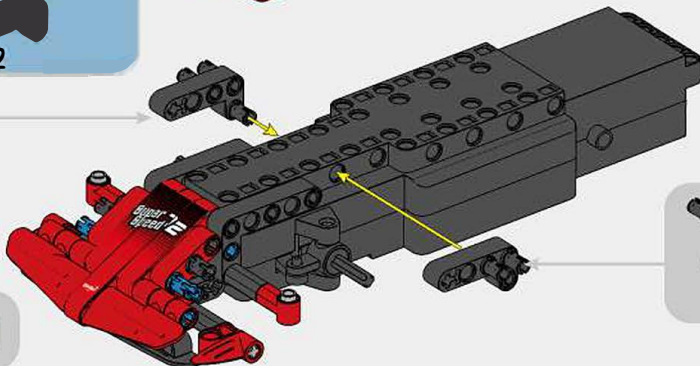
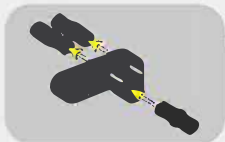

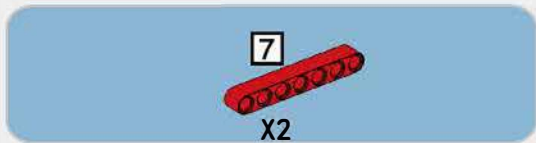

16

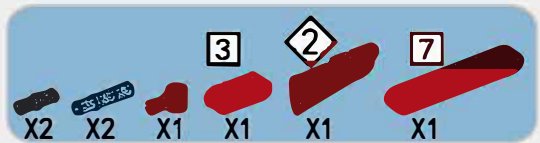
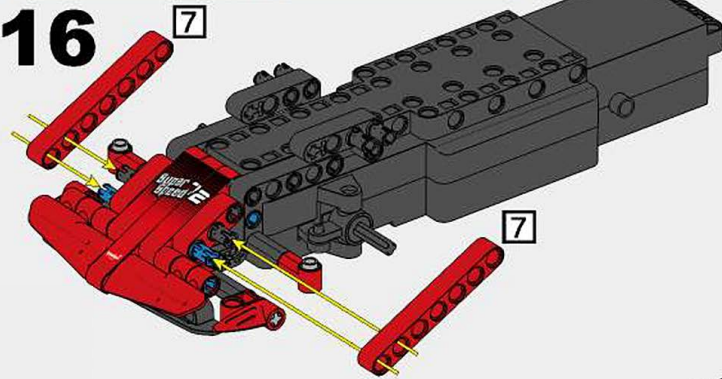

17

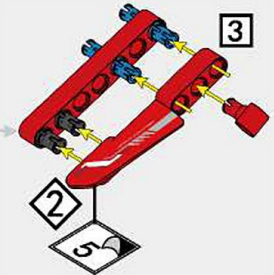
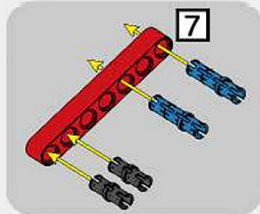

18

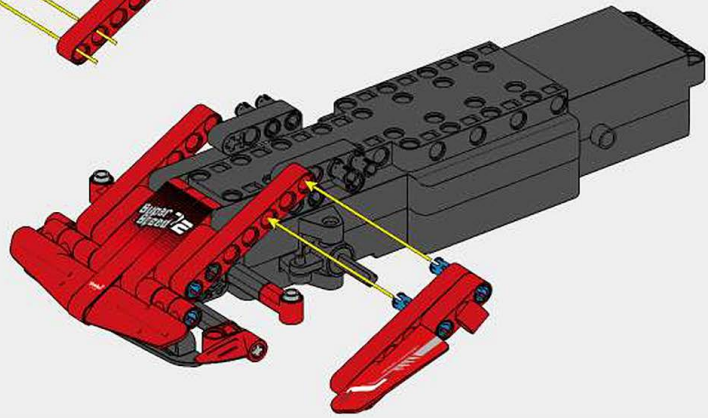

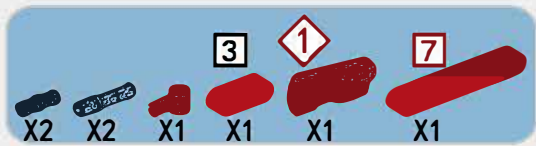

19

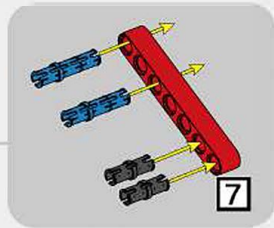
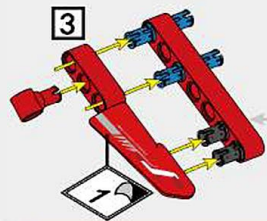

20

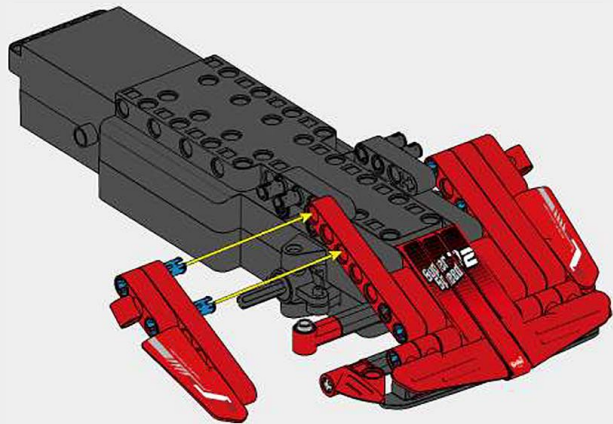

21

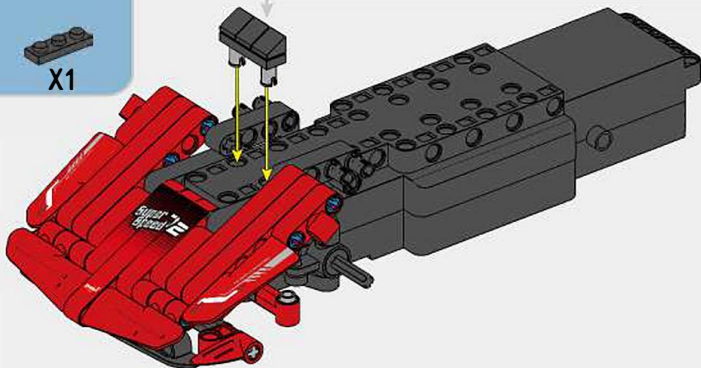

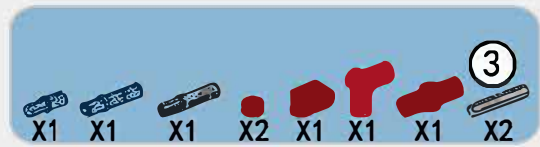

22

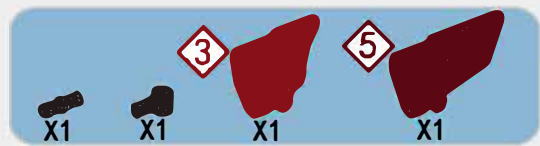
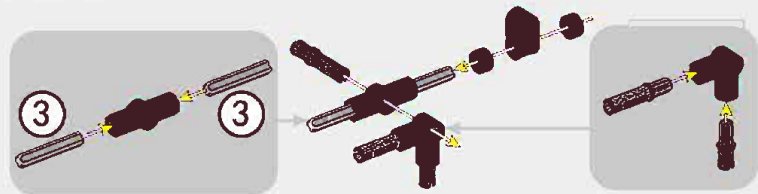

24



25

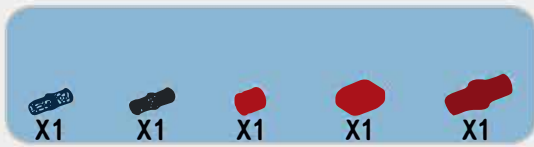
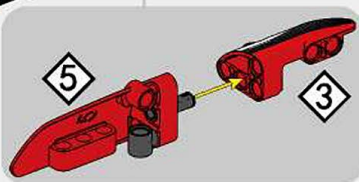

23

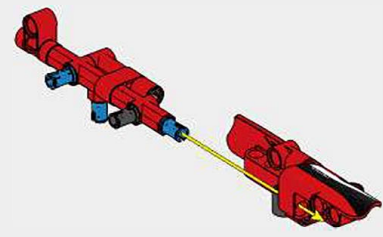
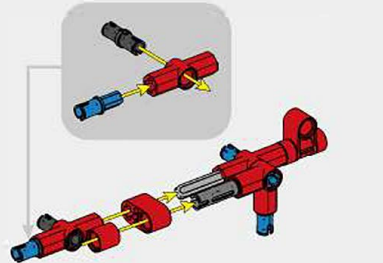

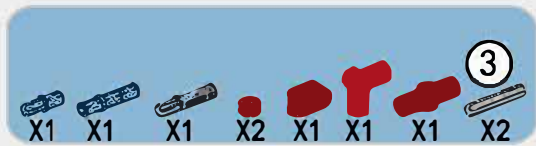

30

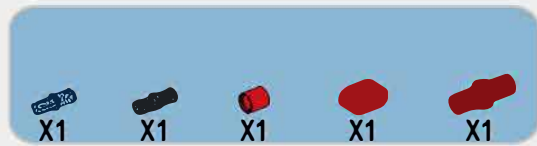
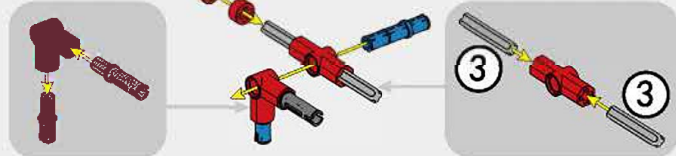

31

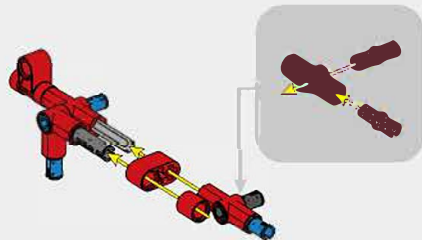

32



33

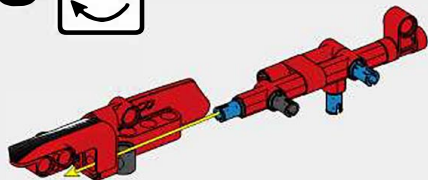

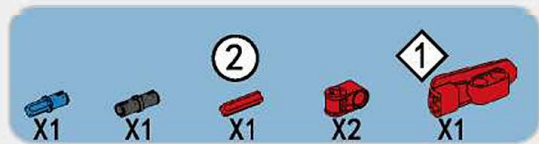

34

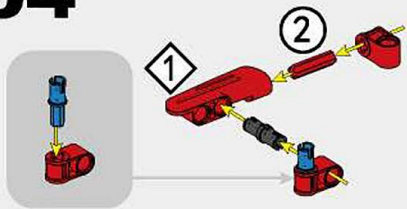

35

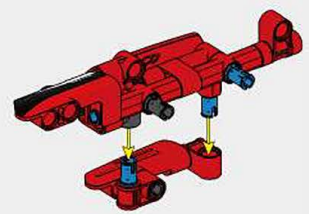

36

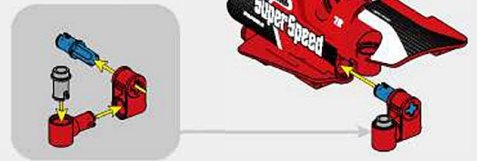

37

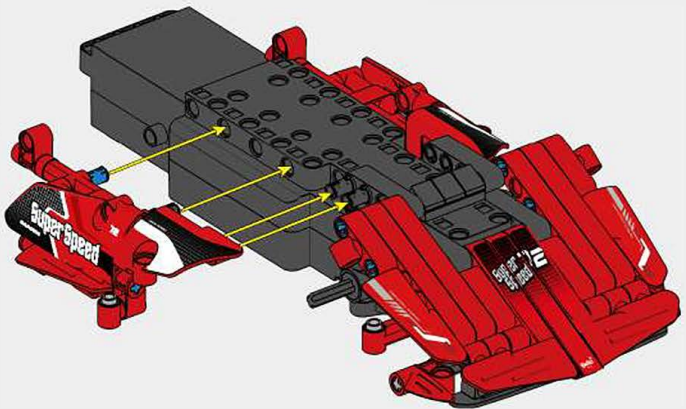



38

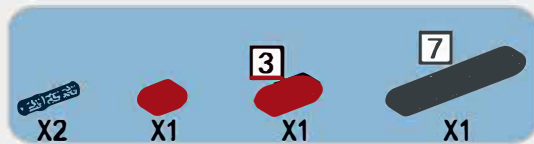
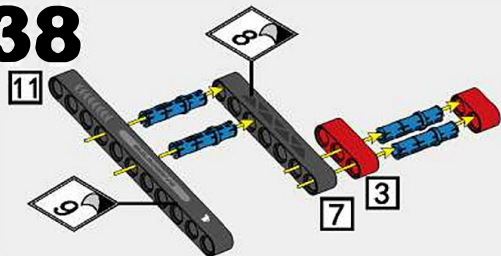

39

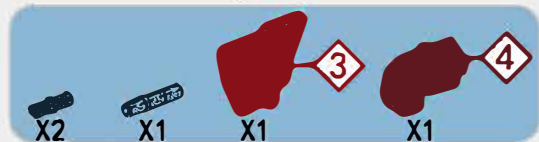
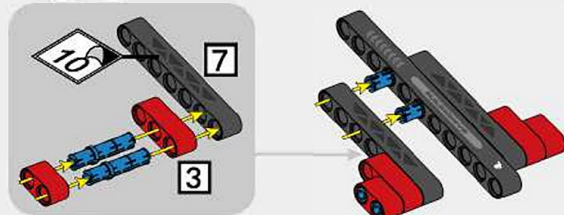

40

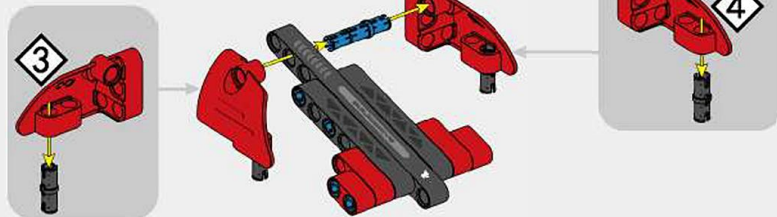



41

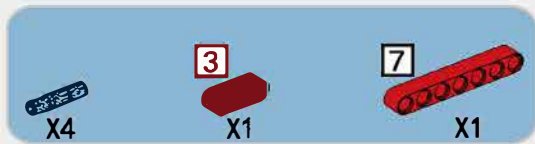
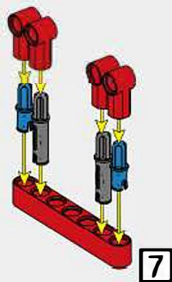

42

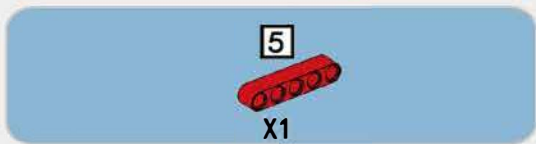
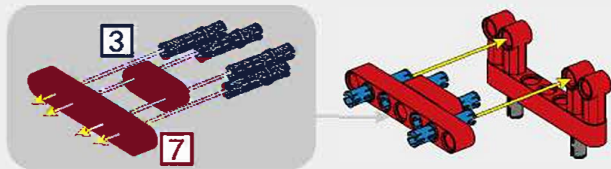

43

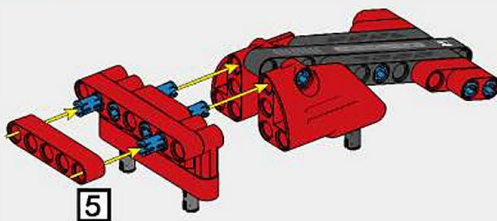

44

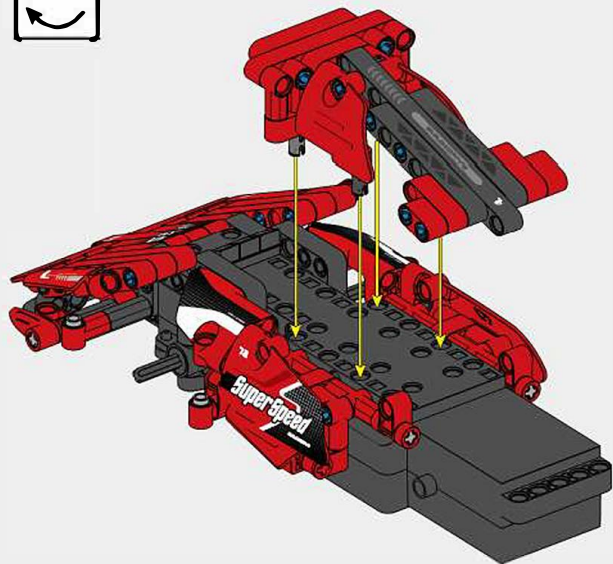

45

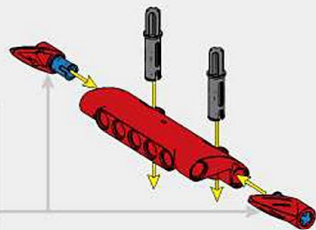

46

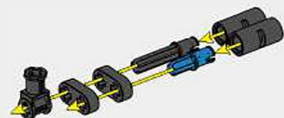



47

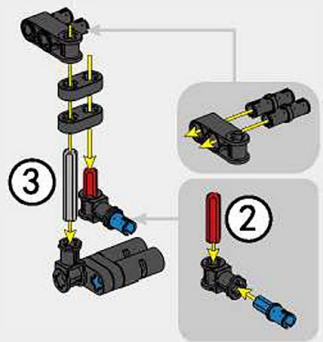

48

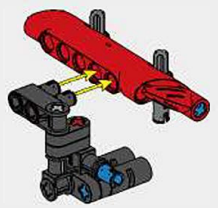

49

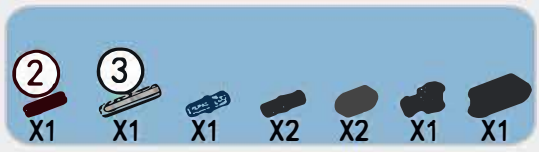
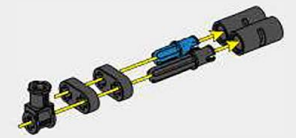

50

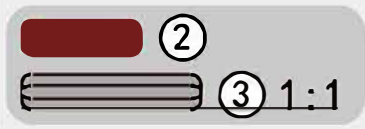
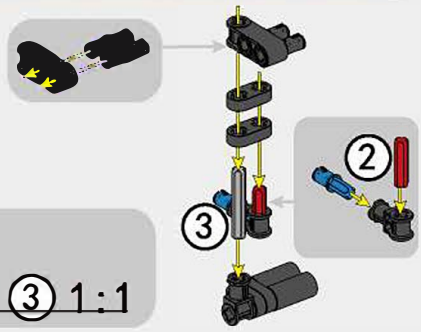



51

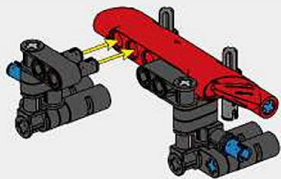

52

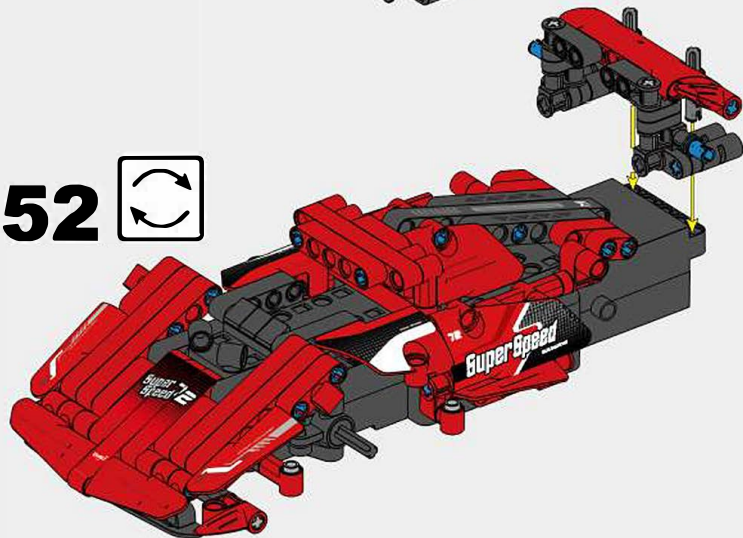

53

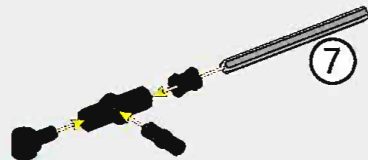

54

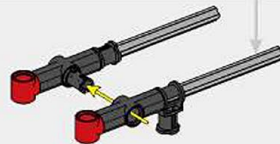
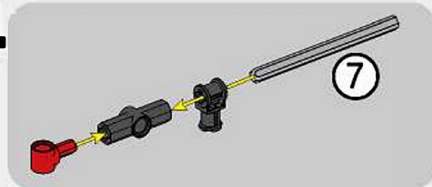



X3

55

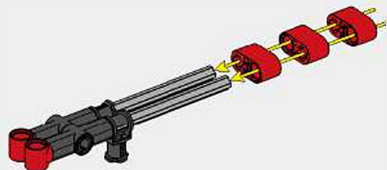

X1



X1



X1



X2



X2

56

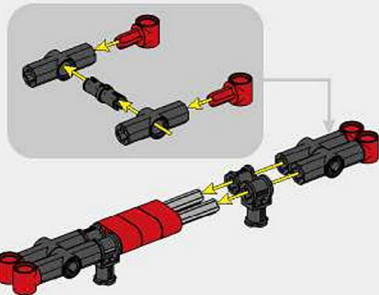

X2



X2



X2

57

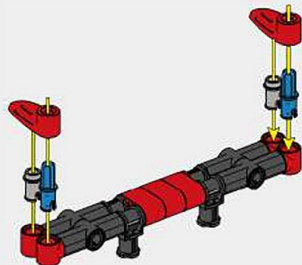

58

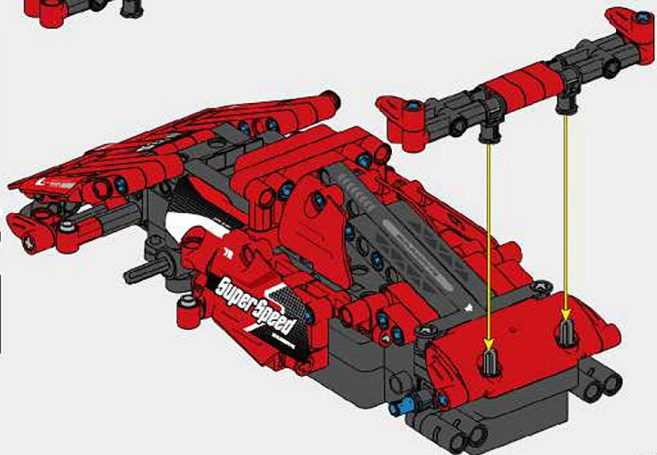

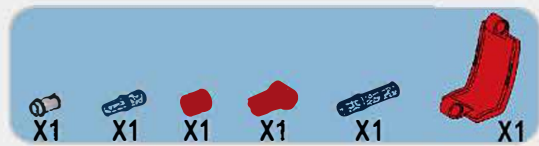

59

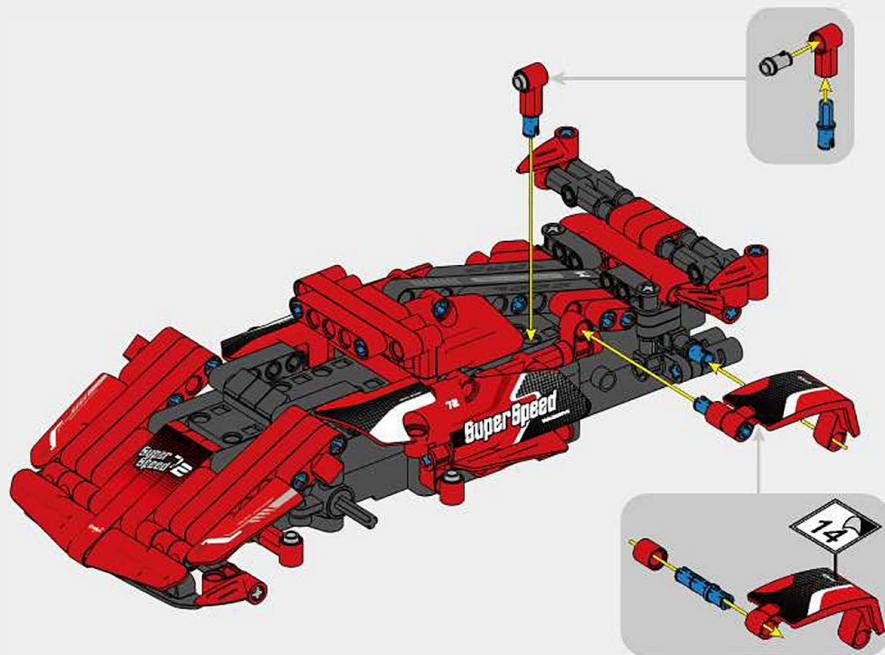

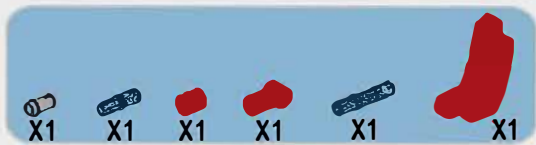

60

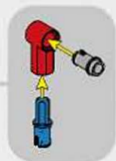
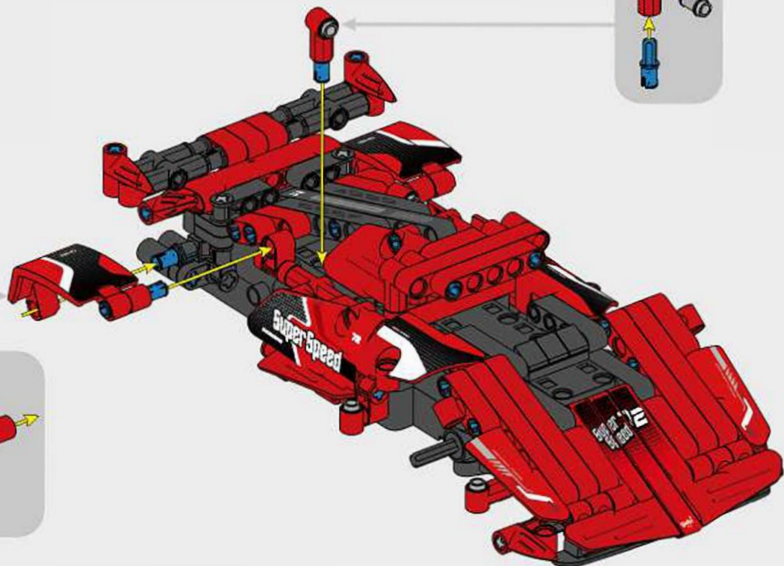
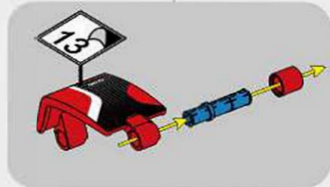

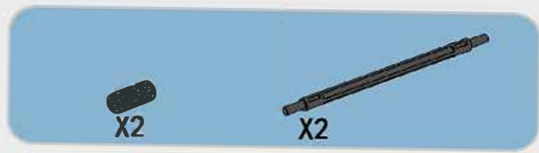

61

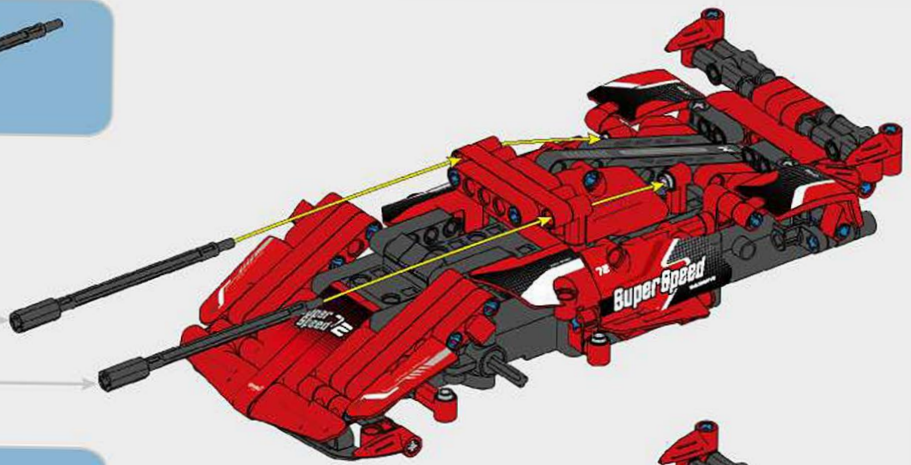
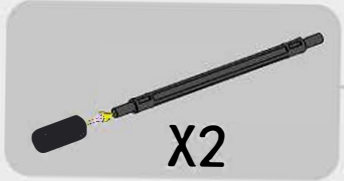

62

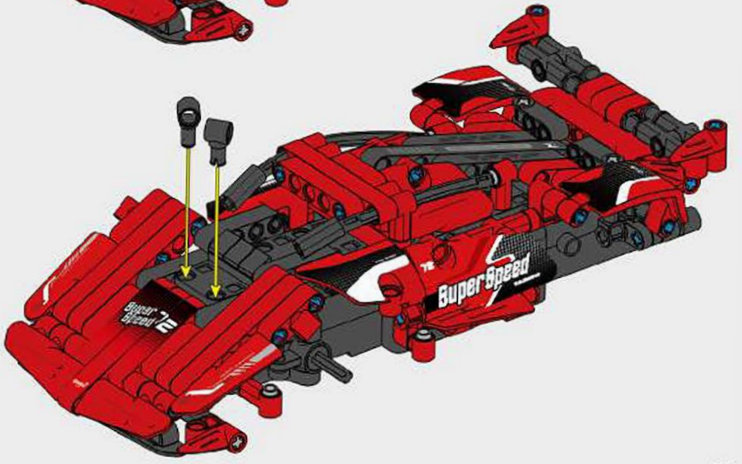



X1

63

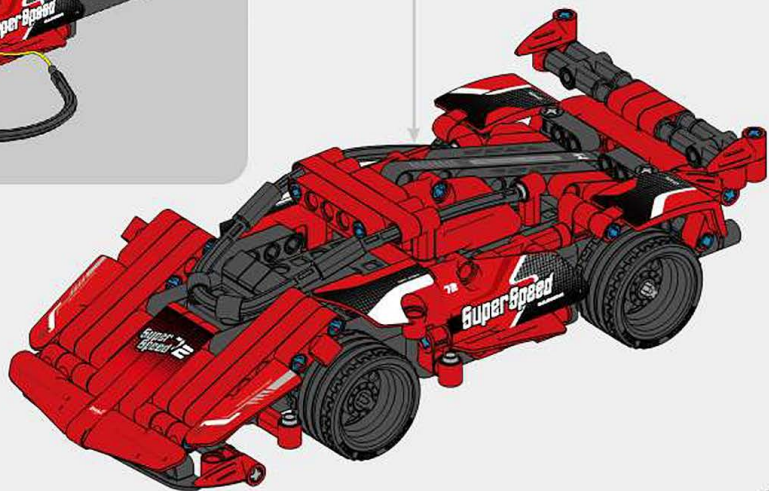
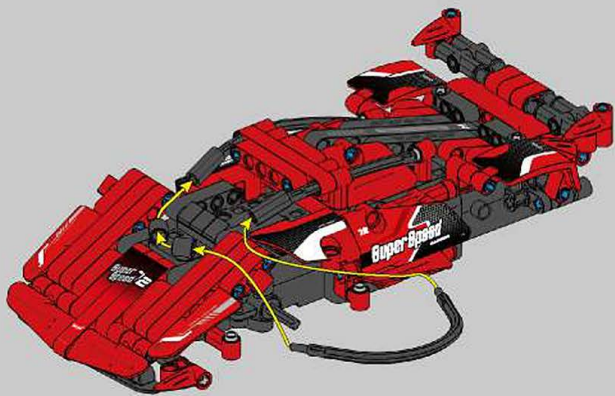



X1

64

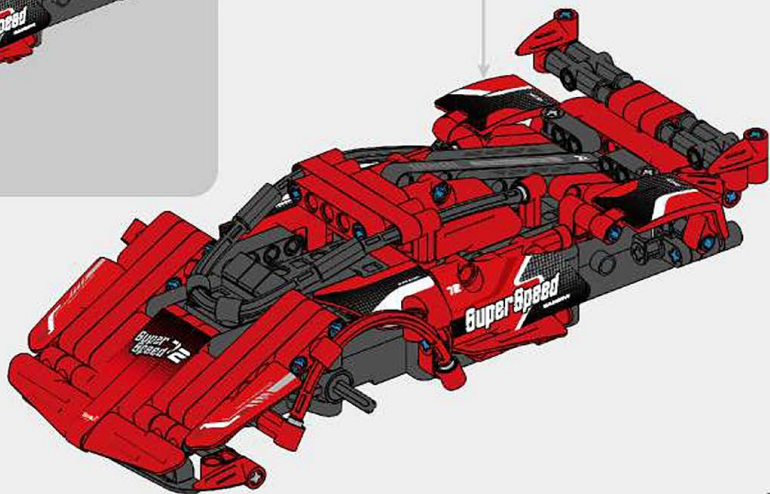
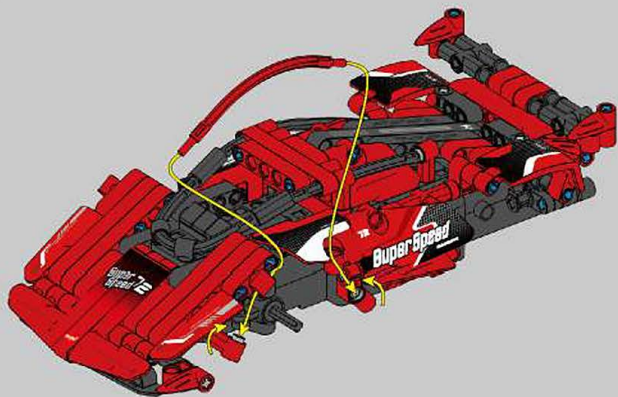



X1

65

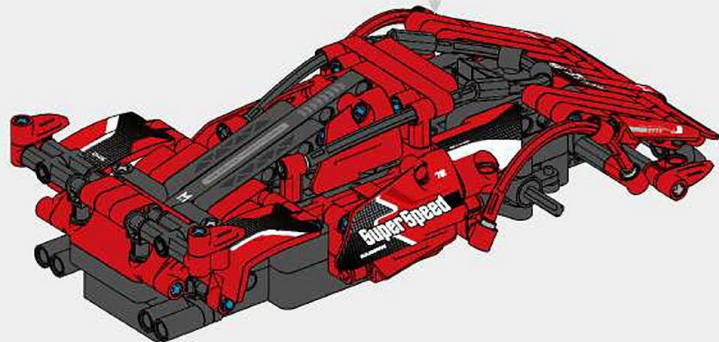
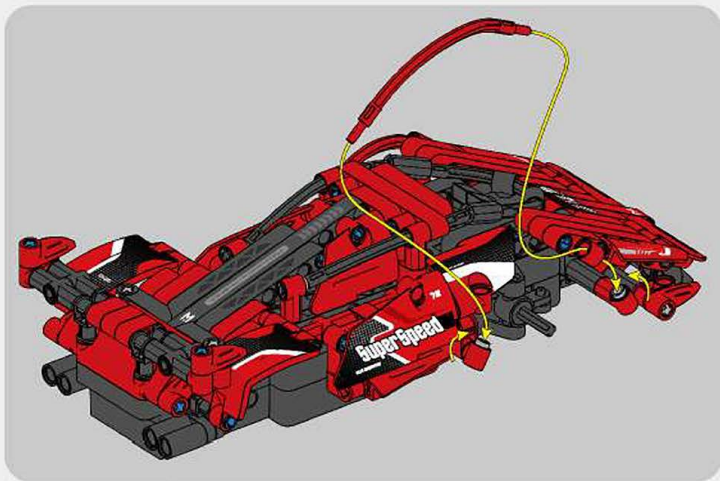

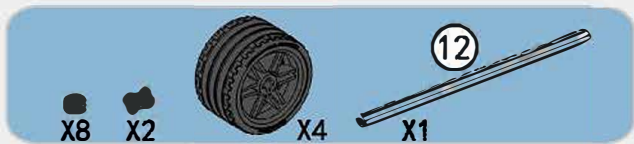

66

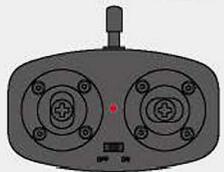
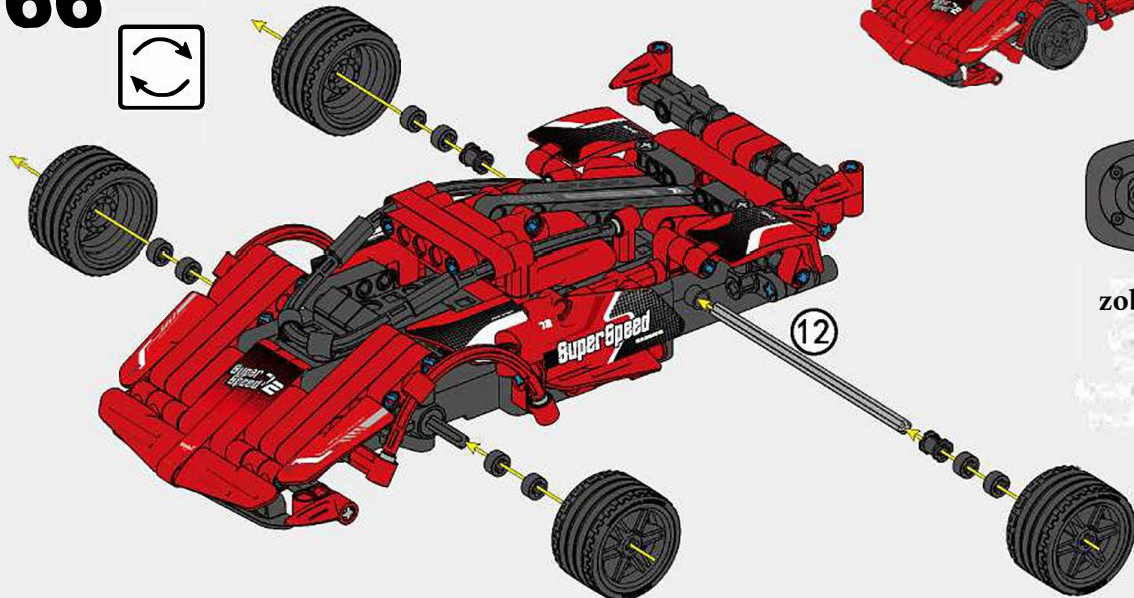

zobacz str. 49



B

Kabriolet

Kabriolet (1/2)

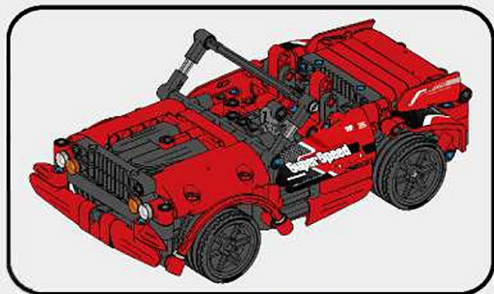

1

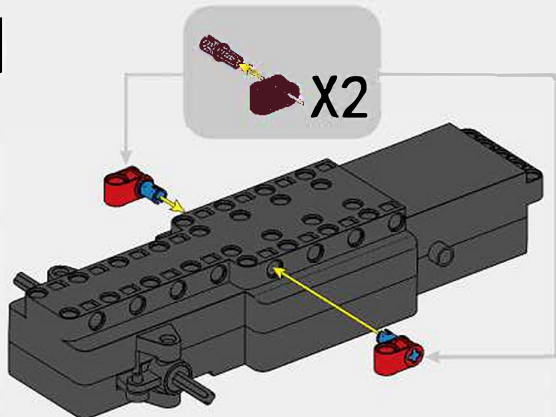

2

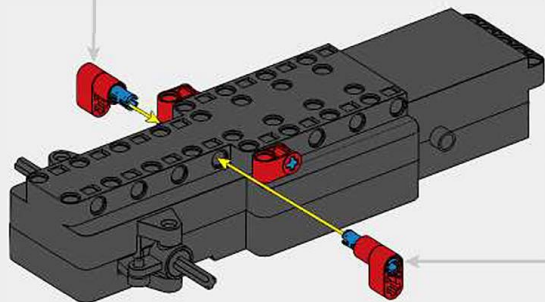
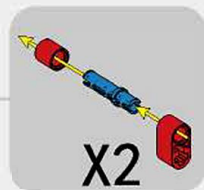

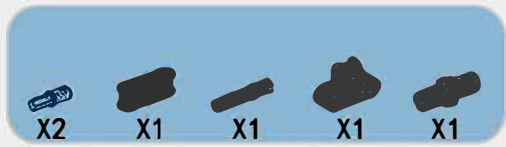

3

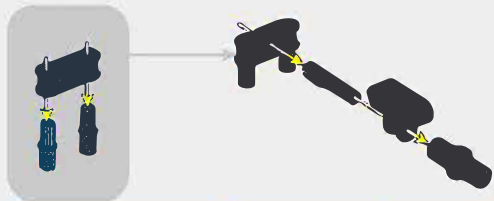

5

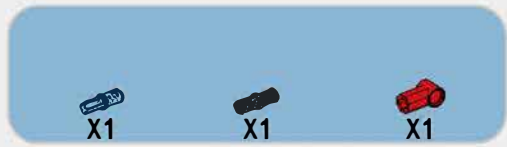
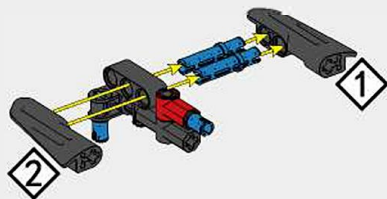

4

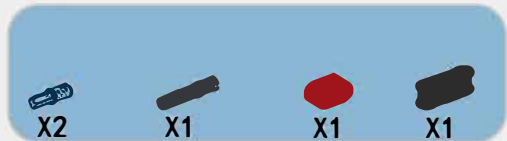
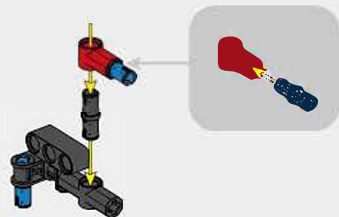

6

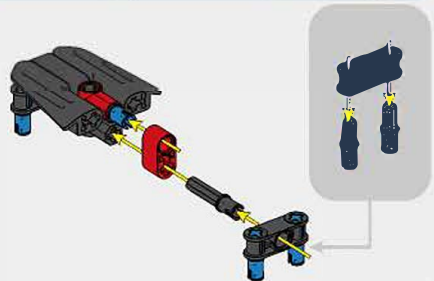

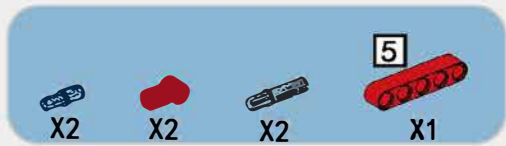

7

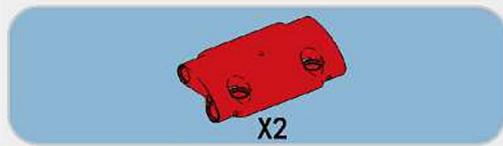
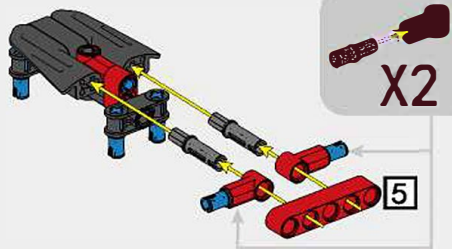

8

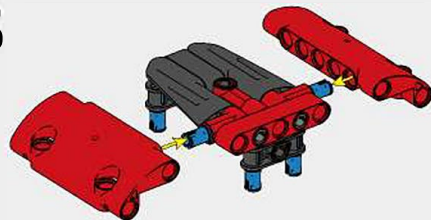

9

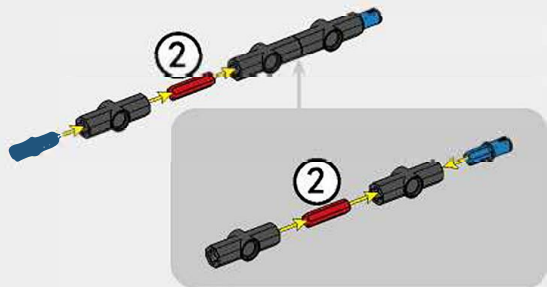

10

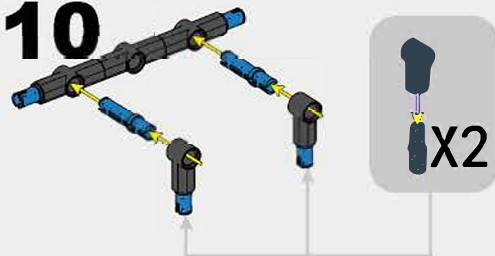

11

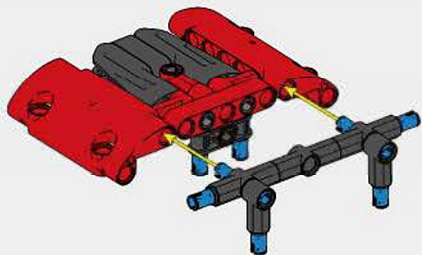

12

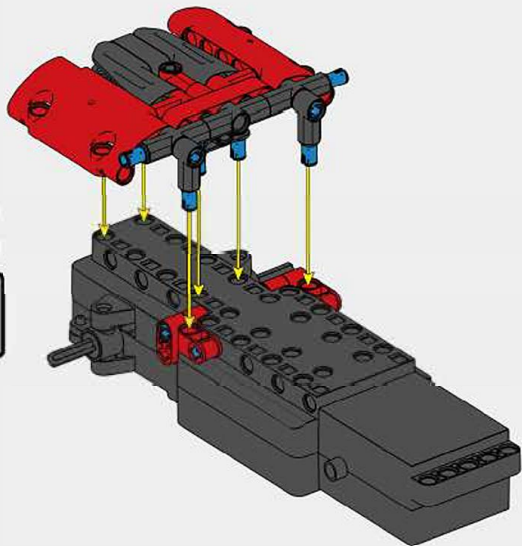

X2

2

X1

X1

X1

13



2



2

1:1

X2

5

X1

14



5



⑤ 1:1

15

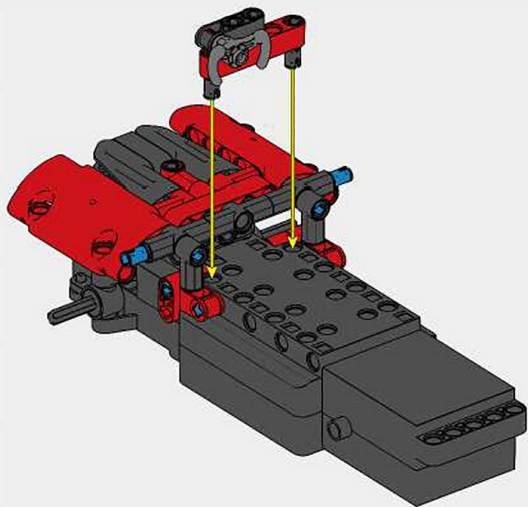

X1

X1

X2

X1

⑤

X1

16

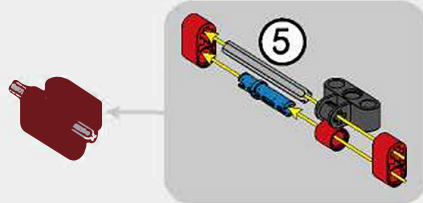

⑤

X2

X2

X2

①

X1

②

X1

17

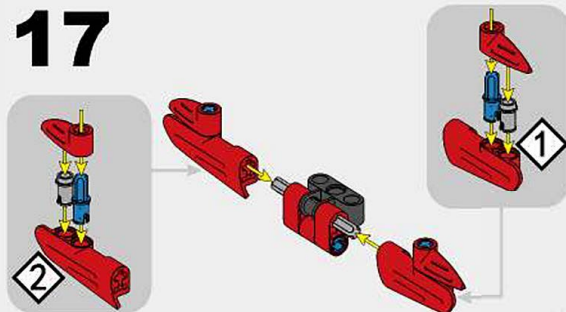

②

①



18

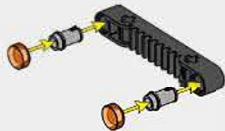

19

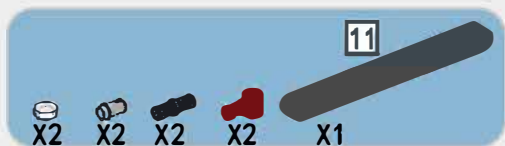
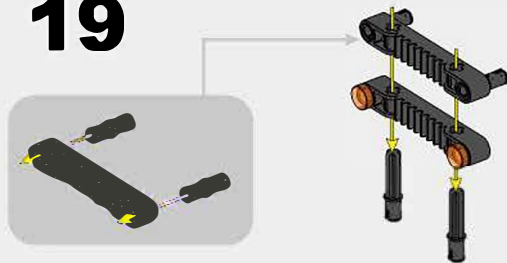

20



X2

X2

X4

X2

21

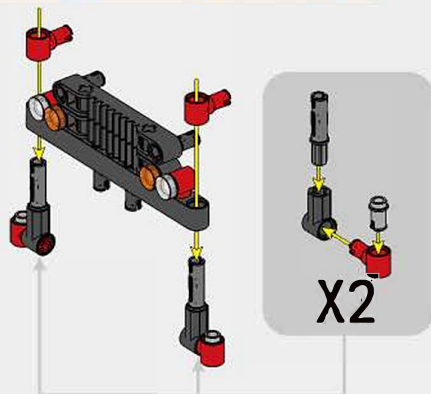

22

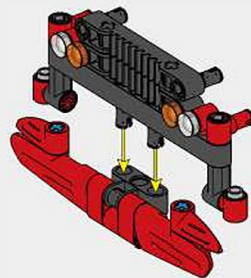

23

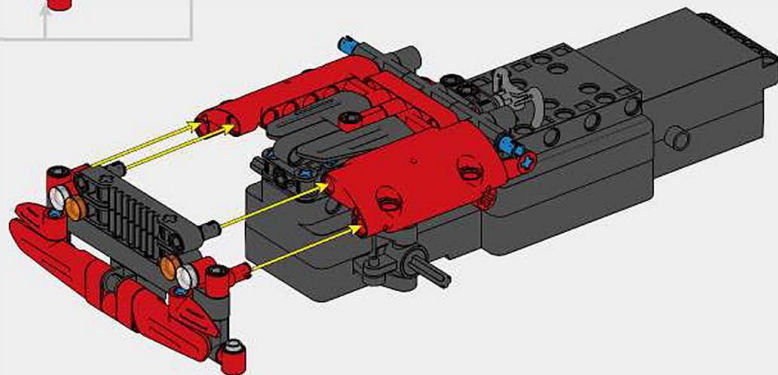

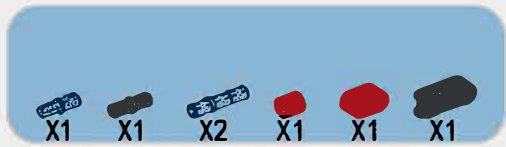

24

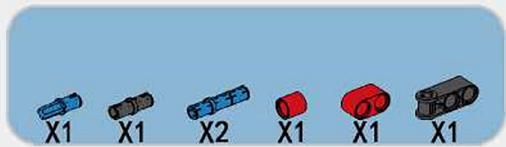
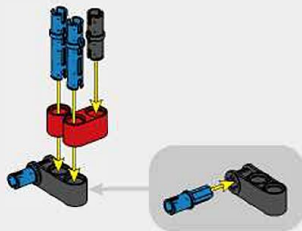

26

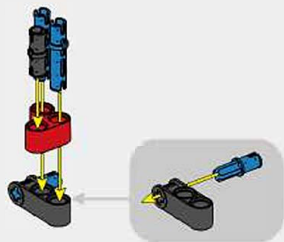

25

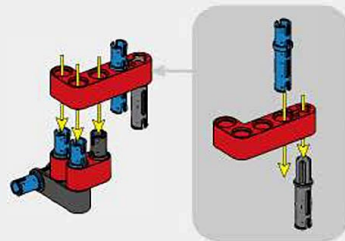

27

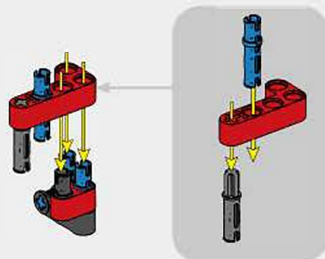

7



X1

28

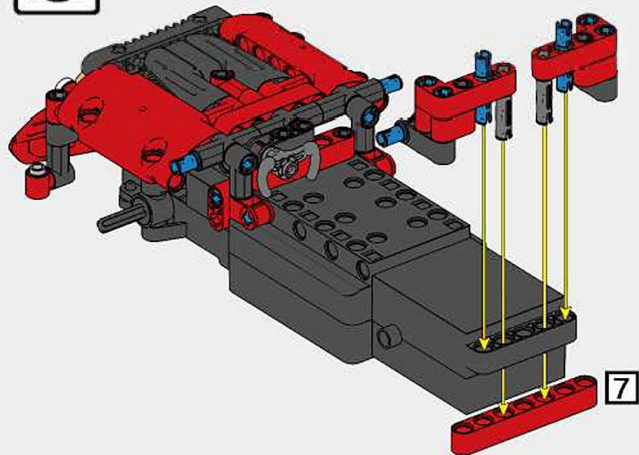

7

7



X3

X4

X4



X1

29

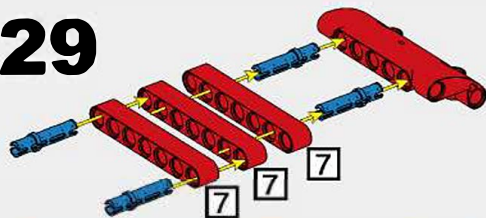

7

7

7

1

2

X2

X2

X2

X2



X1



X1

30



1



2



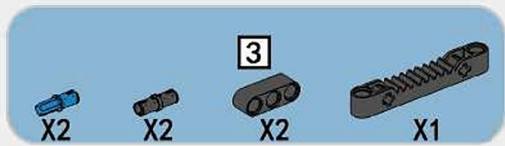

31

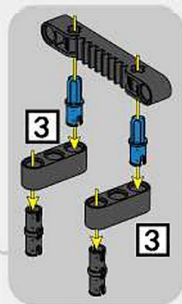
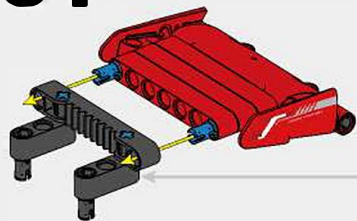

32

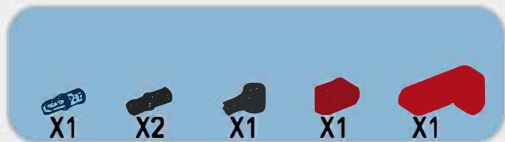
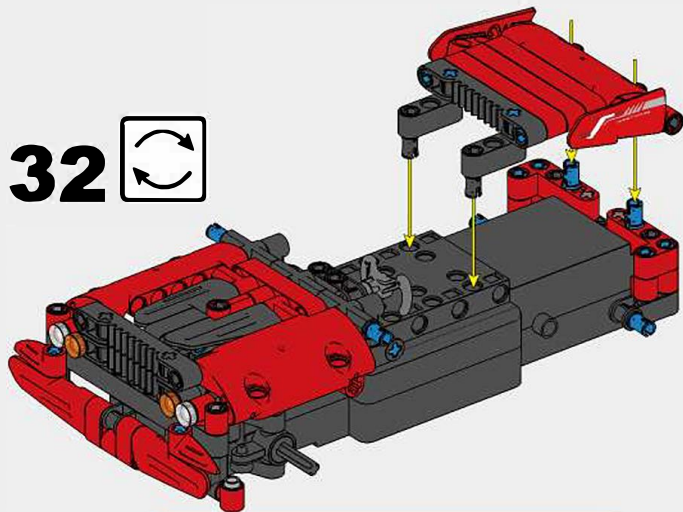

33

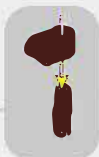
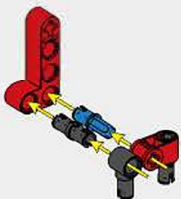

34

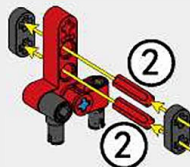

35

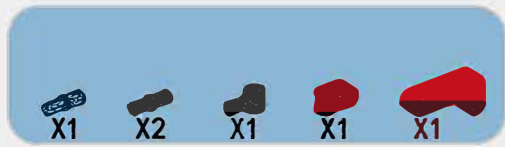
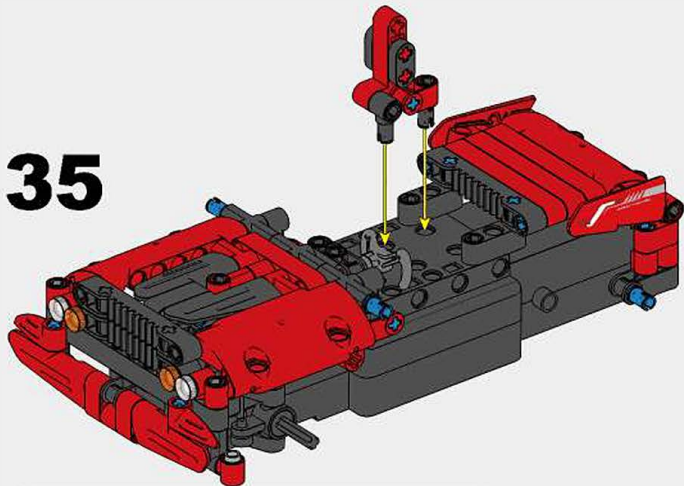

36

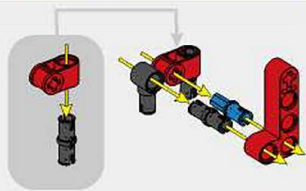

37



38

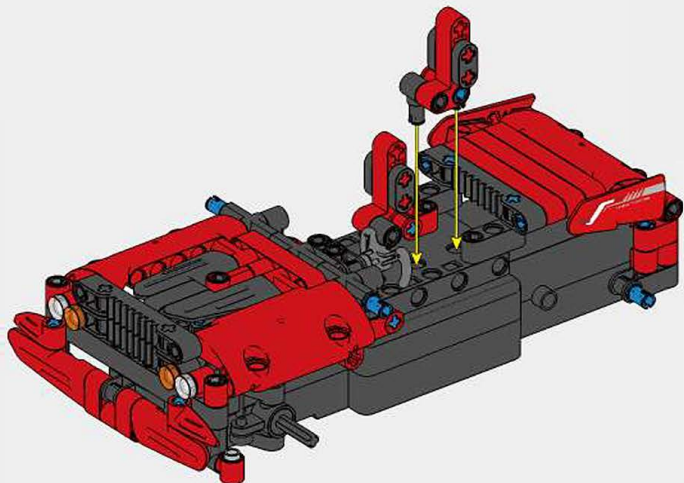



39

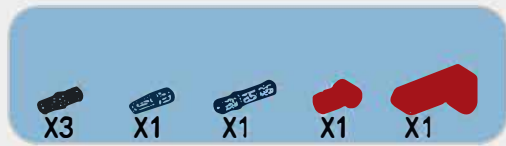
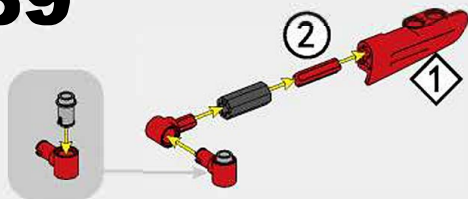

40

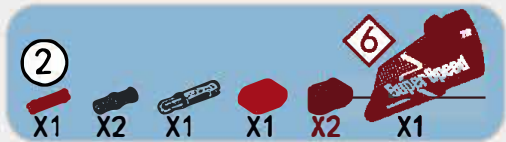
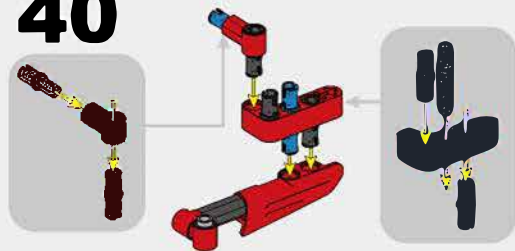

41

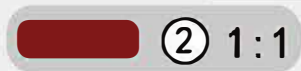
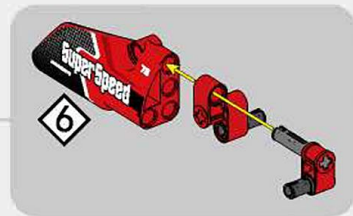
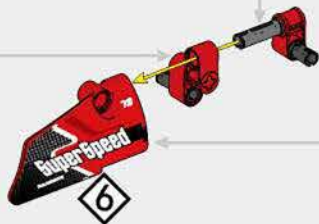
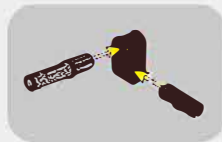
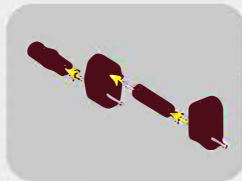

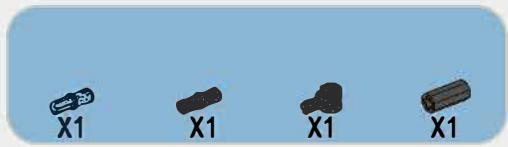

42



43

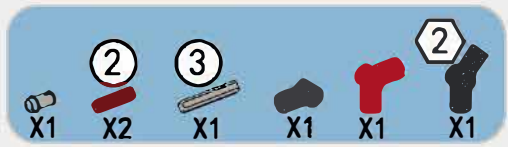
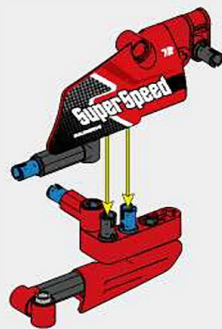

44

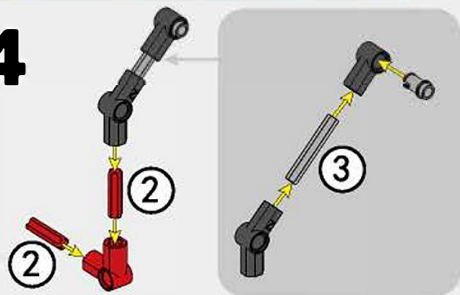

45

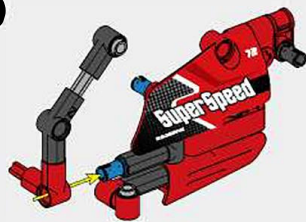
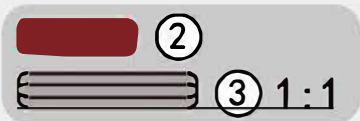

46

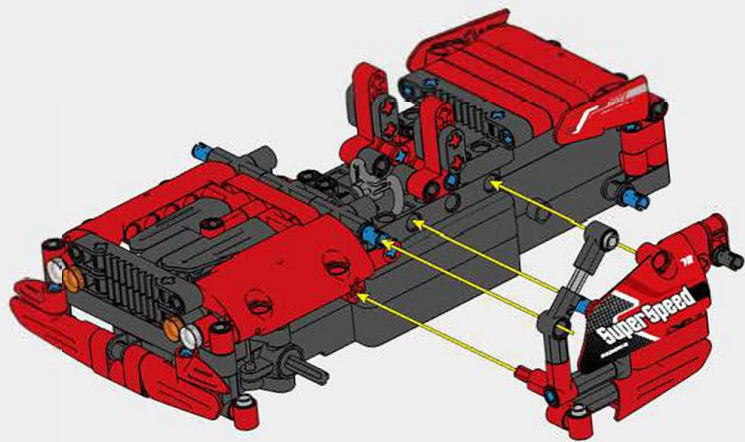

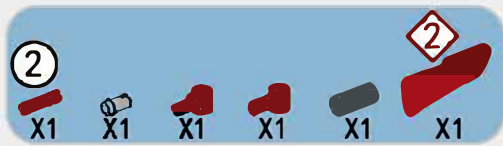

47

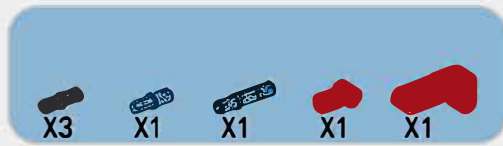
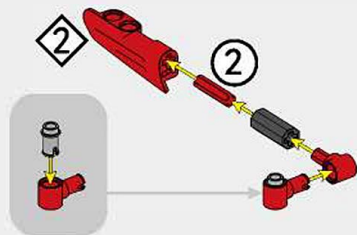

48

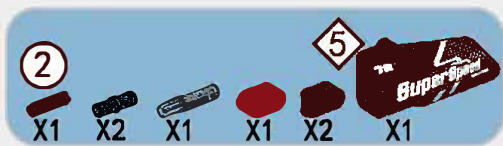
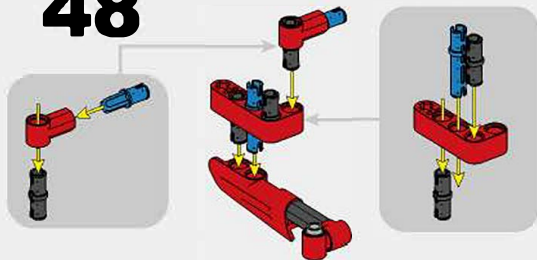

49

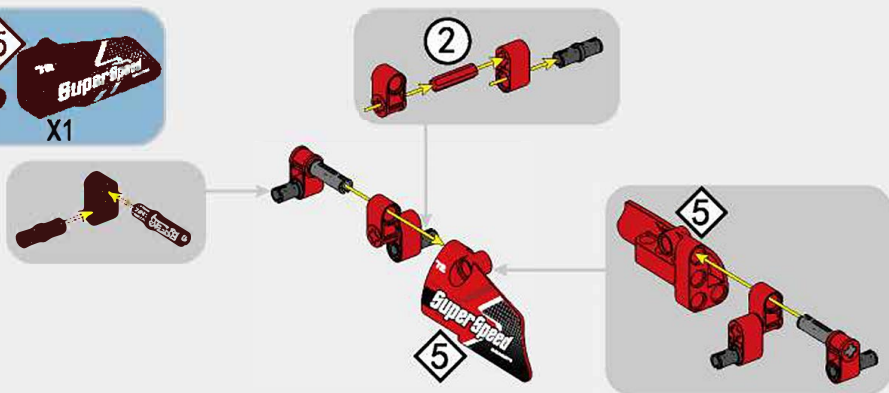

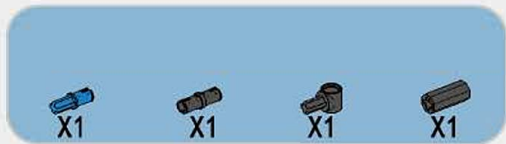

50

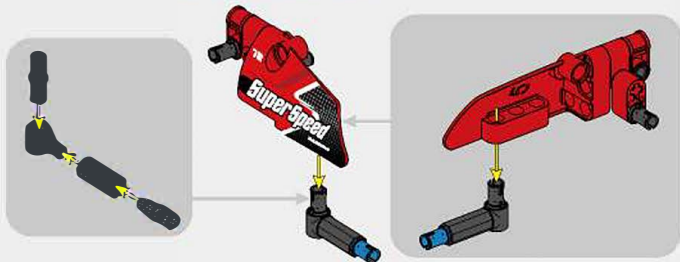

51

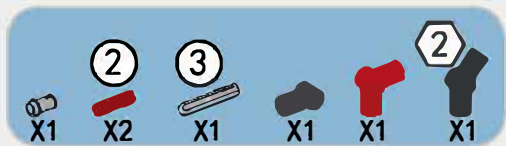

52

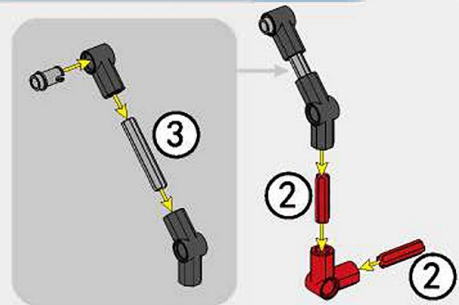

53

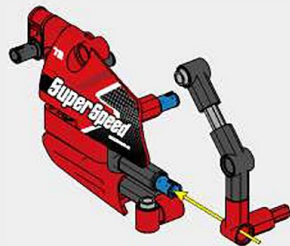



X1

54

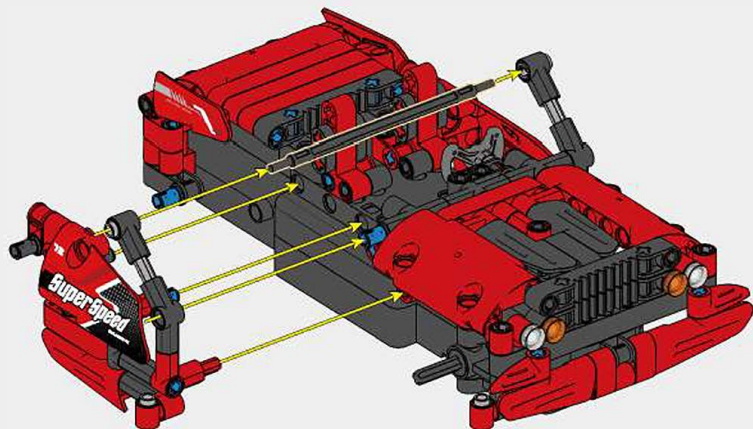



X1



X1

55

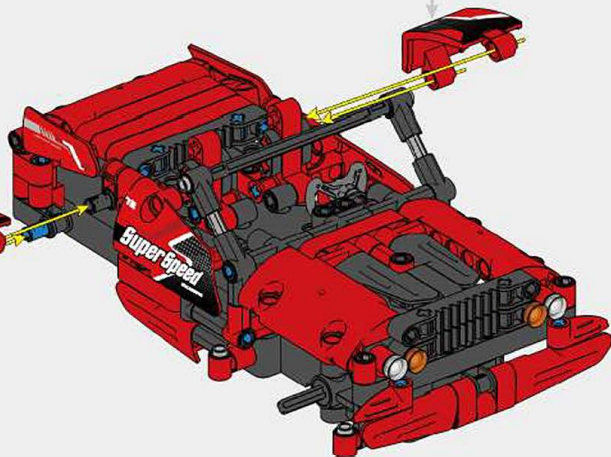
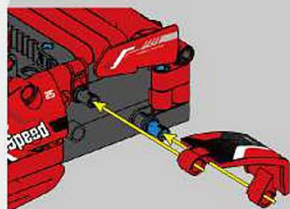



X1

56

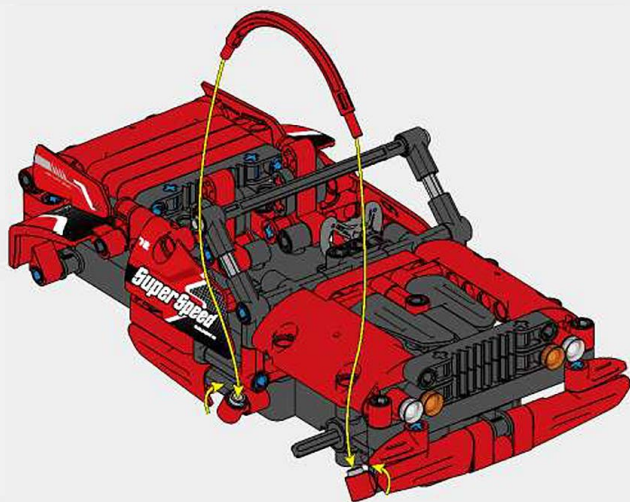



X1

57

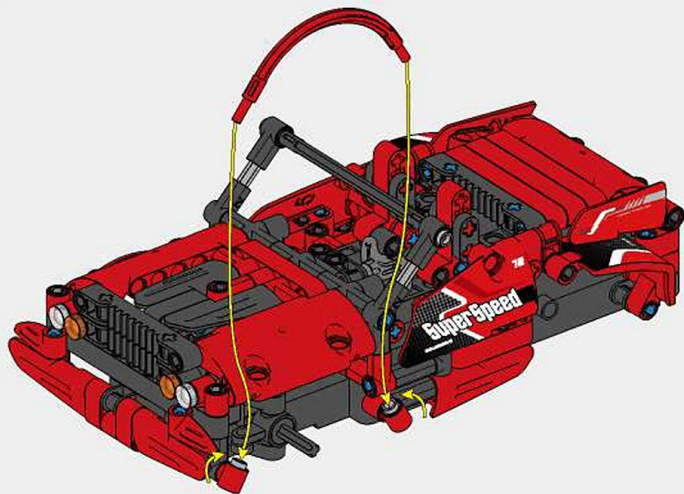



58

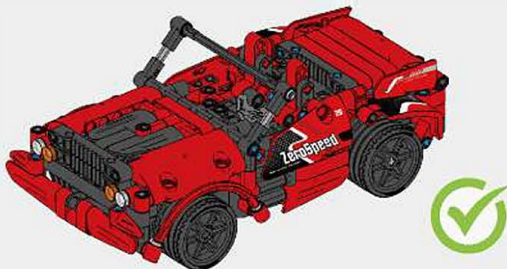
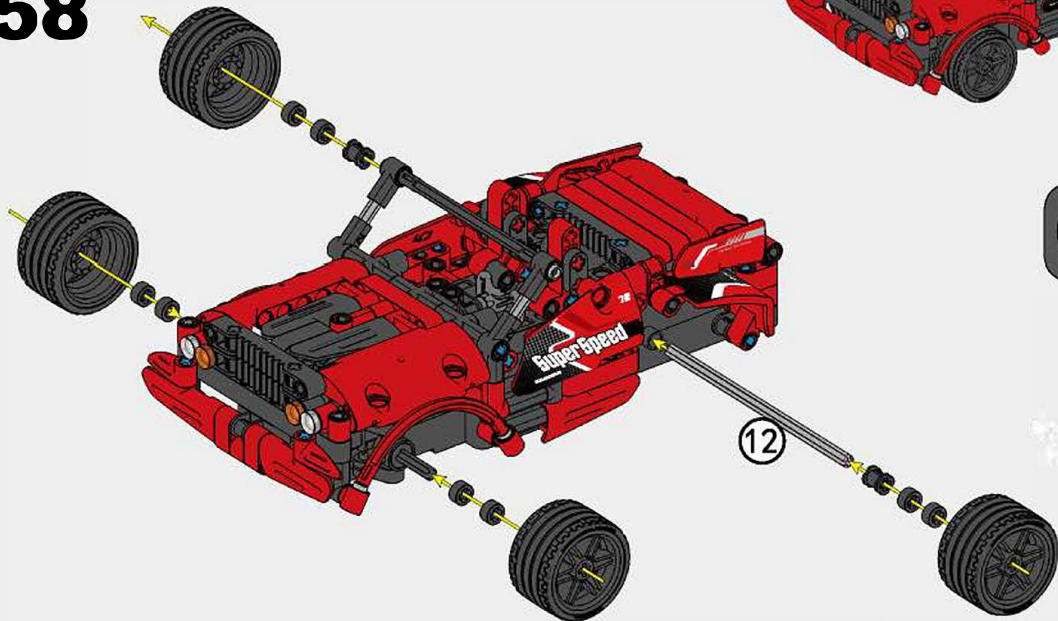

Zobacz str. 49



12 1:1

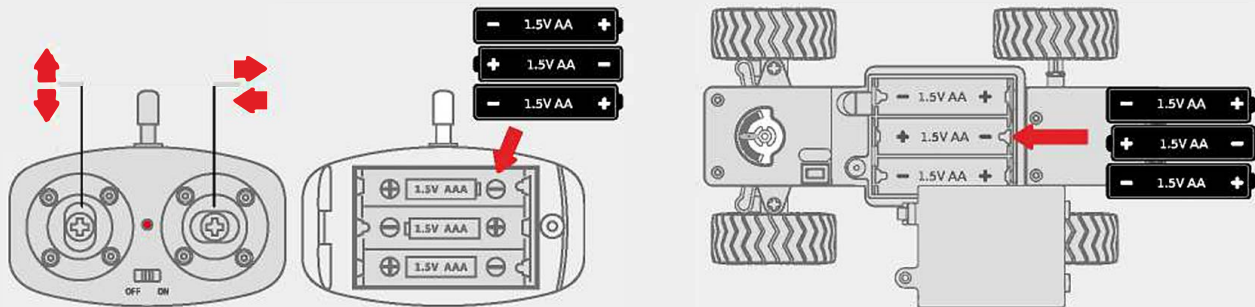

Pilot: wymagane 3 baterie LR03-AAA (niezawarte w zestawie).
 Silniki: wymagane 3 baterie LR06-AA (niezawarte w zestawie).
 Baterie powinny być wymieniane przez osoby dorosłe.

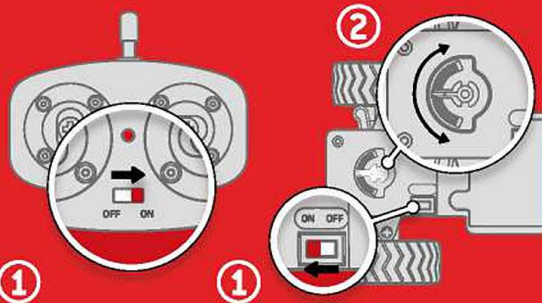

1. Przelącz przycisk na ON. Lampa LED na pilocie powinna się stale świecić.
2. Skoryguj wyważenie kół.



NAUKA JAZDY



1	2cm	7cm	10cm
2	1min	2min	3min
3	15sec.	30sec.	60sec

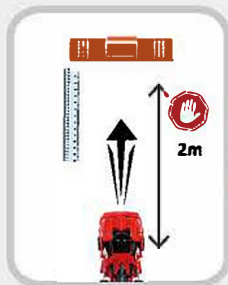

1 TEST HAMULCÓW

Umieść książkę i linijkę, tak jak pokazano na obrazku. Zaczynij test z odległości około 2 metrów. Przyspiesz maksymalnie, a następnie zahamuj jak najbliżej książki.

2 SLALOM

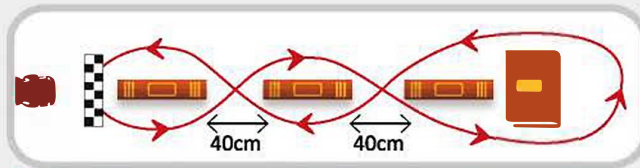

Umieść cztery książki, tak jak pokazano to na obrazku. Ustaw samochód na linii startowej i pokonaj trasę tak szybko jak to możliwe.

3 PARKING

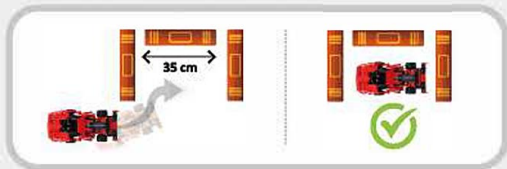

Umieść trzy książki, tak jak pokazano to na obrazku. Ustaw samochód na linii startowej i uruchom stoper. Zaparkuj samochód tak szybko jak to możliwe.

4 PRO-DRIVER



Stwórz kilka zakrętów na podłodze: 45°, 90°, 180°. Kiedy zbliżysz się do zakrętu, ustaw auto na zewnętrznej stronie trasy, następnie skręć kołami w kierunku kąta i zmniejsz prędkość. Kiedy dotrzesz do miejsca zaznaczonego gwiazdką, zacznij prostować samochód i przyspieszaj za kątem. Stwórz swój własny tor i bij rekordy prędkości.

Wymagane 3 baterie LR06-AA (niezawarte w zestawie) i 3 baterie LR03-AAA (nie zawarte w zestawie).

Zalecamy użycie nowych baterii wysokiej jakości najlepiej alkalicznych lub akumulatorów nadających się do ponownego ładowania.

Baterie powinny być wymieniane przez osoby dorosłe. Nie ładuj baterii do tego nieprzeznaczonych. Akumulatory powinny być ładowane tylko pod nadzorem osoby dorosłej. Akumulatorki powinny być usunięte z zabawki zanim zaczną być ładowane. Nie mieszaj różnych typów baterii ze sobą. Nie mieszaj nowych baterii ze starymi. Baterie powinny być umieszczone zgodnie z polaryzacją (patrz obrazek). Zużyte baterie powinny być usunięte z zabawki. Końcówki baterii nie mogą być narażone na spięcie. Baterie powinny być umieszczone zgodnie z polaryzacją (patrz obrazek). Zużyte baterie powinny być usunięte z zabawki. Końcówki baterii nie mogą być narażone na spięcie.



Développé et distribué par :
Developed and distributed by :
BUKI France
22 rue du 33ème Mobiles
72000 Le Mans - FRANCE
Tél: +33 1 46 65 09 92
E-mail : daniellevy@bezeqint.net
www.bukifrance.com

UK
CA

CE



8+

BUKI
DRIV